



Capacity Credit value of Wind in a Balanced Portfolio



Authors: Bhavya Gudimetla, Dr. Johan Enslin, Dr. R. G. Ramakumar
4020 Westchase Blvd., Suite 300
Raleigh, NC 27607
JEnslin@Quanta-Technology.com
919-334-3037 (Office)
919-303-1574 (Mobile)

Capacity Credit value of wind in a balanced portfolio

Wind electric conversion has become one of the most promising technologies to address the various energy issues facing the United States. National initiatives such as “20% electricity from wind by 2030” and grand plans to replace some of the gas-fired electric generation by wind so that the saved gas can be used in compressed form to power automobiles leading to a decrease in importation of petroleum are manifestation of the progress made just in the past decade. Among the many issues for consideration as the penetration of wind generated electric power into conventional power systems increases, quantification of “capacity credit” ranks high because of its direct economic impact.

The purpose of this study is to develop a simplified method to evaluate the capacity credit of wind electric conversion systems (WECS). The simplified approach presented in this study employs an effective forced outage rate for a wind generator and uses the classic loss of load probability calculations to estimate the capacity credit. The result is a good estimate of capacity credit and it can be followed by detailed calculations as needed. The study presented provides a simplified reliability model for the output of a WECS for the use in the capacity credit evaluation of a hybrid system. Results of sensitivity analyses are presented to study the impact of penetration levels, amount of spinning reserve, wind parameters. The method can be extended to include the effect of seasonal changes, impact of variable load on capacity credit. The approach presented can be used in reserve capacity planning in which coal-fired plants will be replaced by WECS.

Case Study: ERCOT

Importance of Wind Energy

Fossil fuels (coal, oil and natural gas) account for nearly two-thirds of electricity generation even as late as 2005.¹ Electricity generation and consumption has tripled over the past three decades as shown in Figure 1. The associated emission of greenhouse gases (primarily carbon dioxide) and its impact on global climate change have attracted considerable attention during the past few years. Coupled with the economic and geopolitical implications of importation of fuels, the need to transfer some of the energy needs to renewable energy resources is becoming increasingly critical. The practical definition of renewable energy is a flow of energy that is not exhausted by being used.²

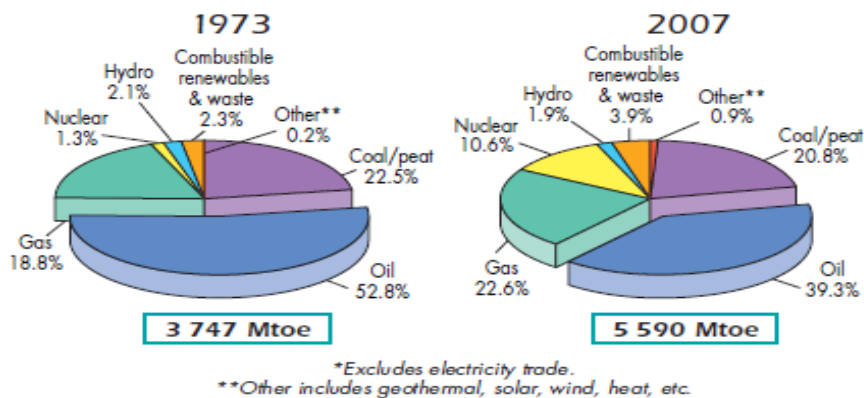

Figure 1: World Electricity Generation, Source: IEA key world energy statistics 2008¹



Of all the renewable energy resources, wind energy has become very popular for electricity generation due to the following reasons: It has a long history of use by human beings. The footprint is very small. The resource base is very large and is distributed throughout the world. Wind energy can be easily converted to rotary mechanical energy. Wind generated electricity has shown great growth over the last two decades. The cost of electricity from wind has dropped from \$0.35 per kilowatt-hour (kWh) in 1980 to less than \$0.05 per kWh today at good wind sites.

Capacity Credit

Capacity Credit (CC) assigned to a renewable power plant is the fraction of its installed capacity by which the conventional power generation capacity can be reduced without affecting the benchmark quality of supply.³ In broad terms, it can be said to be the amount of conventional resources (mainly thermal) that could be 'replaced' by the renewable production, without making the system less reliable.⁴

Factors Determining Capacity Credit

The factors determining capacity credit are listed below:

- Penetration levels
- Amount of Spinning Reserve
- Wind parameters
- Base case reliability
- Voltage levels at which the units are connected
- Proximity to the load centers
- Size of the power system
- Variability of the generator
- Order of correlation of the interconnected wind projects

Capacity credit decreases as wind penetration increases. As amount of spinning reserve increases capacity credit decreases. Distributed Generators are rapidly increasing in electrical power systems. Due to low operation and maintenance costs and maturing technology WECS are becoming the primary choice among renewable energy sources. Capacity credit variation with factors such as base case reliability of the network, voltage levels at which the WECS are connected and their proximity to load centers are discussed in ⁵. Capacity credit does not vary with base case reliability. Generators connected at higher voltage levels will result in high capacity credit value. Generators located near load centers provide for a higher capacity credit value. Wind Load Carrying Capability (LCC) can be calculated using probabilistic approach and stochastic models which are computer intensive. One approach that has been proposed to estimate LCC from power plants is the constant z-statistic method.⁶ The following are the factors affecting capacity credit - larger power systems will contribute to a greater capacity contribution from a given power plant than that realized with smaller power systems, generators with greater variability over peak demand hours result in lesser contribution to meeting peak loads, Capacity contribution from correlated wind projects depends on the order of interconnection.⁷

Approach to Calculate Forced Outage Rate (FOR) Of WECS

The FOR of a wind-electric system is comparatively higher than that of conventional generating units due to the stochastic nature of wind, operating characteristic and mechanical components failure which may result in zero output power. FOR of WECS can be calculated by considering the characteristics of the wind resource, output curve of the WECS and mechanical failure data.

From the power output curve of WECS shown in Figure 2, it can be seen that wind-electric system starts generating electric power at a wind speed known as cut-in speed (V_{ci}), reaches rated power (P_r) at rated wind speed (V_r) and continues to produce rated power until it reaches cut-out speed (V_{co}). Beyond the cut-out value, the turbine is shut down completely for safety reasons. By approximating the non-linearity in the power curve for wind speeds between V_{ci} to V_r to a straight line, an equation for the power output can be obtained for use in FOR calculations.

FOR of a WECS and reliability model of WECS are discussed in detail in ⁸.

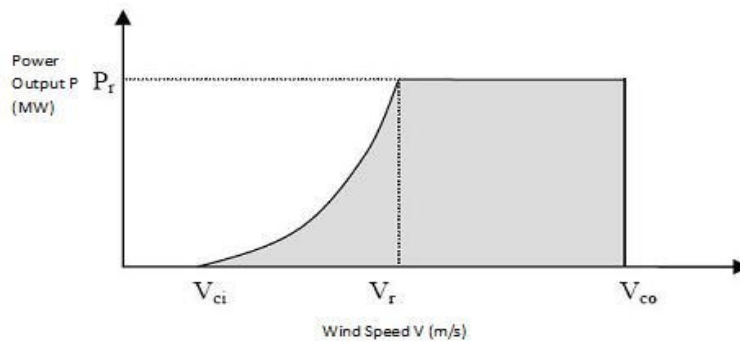

Figure 2: WECS Power Output Characteristic

Approach to Assess Capacity Credit

Life history of a repairable electric power system component during its life period is represented by a two state model, the two states are 'up' or 'available' and 'down' or 'unavailable'. Therefore 'up' state is nothing but 'capacity-in' and 'down' state is nothing but 'capacity-out'. Some of the other parameters involved are listed and defined below.

Required Load (L): Power system planning and operation has to be done by properly planning for the load using load forecasting. Required load is the forecasted load.

Capacity in (C_{in}): C_{in} is the capacity of the generation system that is in service

Capacity out (C_{out}): C_{out} is the capacity of the generation system that is not in service

Probability (P): Probability value used for calculation of LOLP is the probability of exactly the indicated amount of capacity in service.



Load Loss (L): Failure of meeting the target i.e., if capacity is greater than the required load then load loss will be zero otherwise load loss is the difference between required load and capacity in.

Loss of Load Probability: A loss of load occurs when system load exceeds the available generating capacity. The overall probability that there will be a shortage of power is called the loss of load probability.

We need to multiply the load loss values by their probabilities and sum them to find the expected loss of load.

Considering the case of a 2-unit plant, there are four system states. For each state, C_{in} , C_{out} , P and L are calculated. Then the expected loss of load can be expressed as $E[\text{loss of load}] = (P_1 * L_1) + (P_2 * L_2) + (P_3 * L_3) + (P_4 * L_4)$

After finding the expected loss of load of a system with conventional generators, wind generator is added next to the system and the decrease in expected loss of load is found. The wind generator is replaced by a conventional generator and the capacity of the conventional generator is changed until we get the same expected loss of load as in the second case. This capacity is the capacity credit that can be assigned to WECS.

Study Example:

For the study, three different wind regimes, labeled as low, medium and high are used and their corresponding weibull parameters are listed in Table 1.⁹ Values of cut-in, rated and cut-out wind speeds are chosen as 3.6 m/s, 8m/s and 21 m/s respectively.

Table 1. Wind Specific Data

Wind Speed	α (m/s)	β
Low	5.07	1.31
Moderate	9.7	2.00
High	15.55	3.10

Table 2 lists the values of WECS reliability and FOR for the three different wind regimes⁸. As expected, high speed wind regime results in higher unit reliability and the lowest effective FOR value.

Table 2. FOR of WECS

Wind Speed	Low	Moderate	High
FOR _{Mech}	0.0059	0.0059	0.0059
R	0.1653	0.5885	0.7892
FOR _{Wind}	0.8347	0.4115	0.2108

Using the FOR values of WECS listed in Table 2, capacity credit is calculated for a system consisting of conventional generators and a WECS generator.

Step 1: Consider a system as shown in Figure 3 consisting of three conventional generators (Nuclear, Coal-fired and C-cycle). Data is a real time data, taken from ERCOT. The forced outage rate is taken as 0.02 and the system load is taken as 332×10^2 MW.

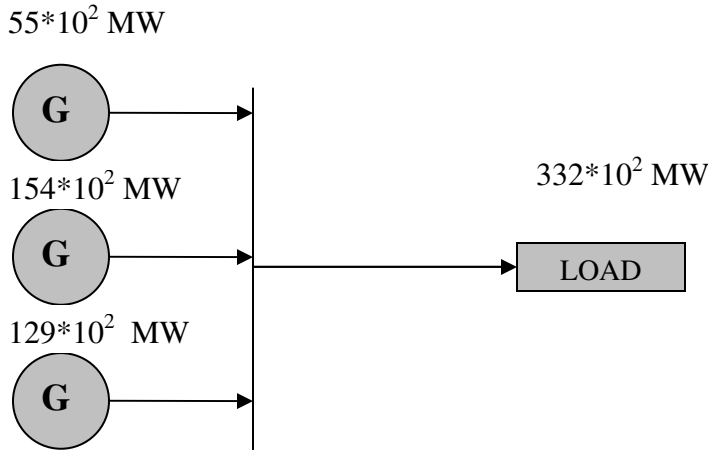

Figure 3: Case of Three Conventional Generators

The expected loss of load of the system is calculated to be 6.407×10^2 MW.

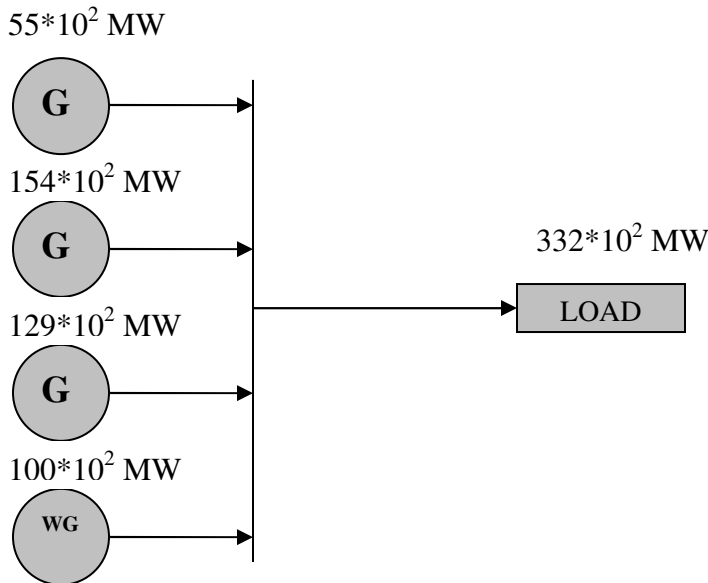

Figure 4: Case of Three Conventional Generators and one WECS

Step 2: A wind generator is added to the system; now the system shown in Figure 4 consists of three conventional coal fired generators and WECS. With the same system

load, the new value of expected loss of load is equal to 3.522×10^2 MW. As expected, the simulation results show a decrease in expected loss of load with the addition of a wind generator.

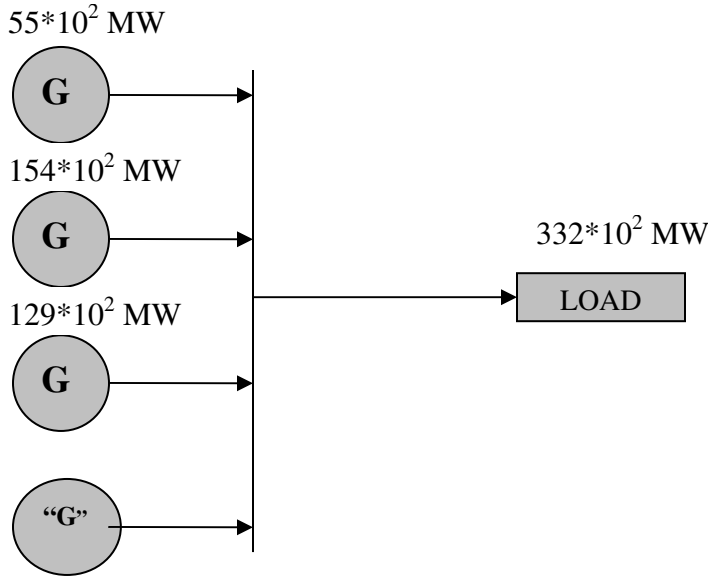

Figure 5: WG replaced by a variable “G”

Step 3: Now the wind generator is replaced by a conventional generator. The capacity of the conventional generator is varied until the same expected loss of load is obtained (3.522×10^2 MW in this case). By using the MATLAB code the capacity of a conventional generator is found out to be 50.97×10^2 MW. Based on this, a capacity credit of 0.5097 can be assigned to the wind system.

Sensitivity analyses is performed to study the impact of penetration levels, amount of spinning reserve, wind parameters and wind turbine output characteristics on capacity credit.

As the scale factor α increases, the capacity credit increases initially and then decreases for high values of α as shown in figure 6. Figure 7 show a steady rise in capacity credit with increasing β at all the three wind speeds. As V_{ci} increases, the capacity credit decreases. As V_{ci} increases, the capacity credit decreases because the wind availability factor decreases with the increase in V_{ci} as shown in Figure 8. With increasing V_{co} , the operational wind speed range increases, rated power is available over a larger range of wind speeds and hence capacity credit increases as shown in Figure 9.

The impact of wind power on system adequacy increases significantly as the capacity of the connected wind farm is increased. Figure 10 shows that the capacity credit of a wind farm decreases rapidly as more wind capacity is added to the system. The results were obtained by adding gradually more wind capacity without changing the reliability level of the system. The variation of capacity credit with change in spinning reserve is shown in Figure 11. As spinning reserve increases, capacity credit decreases.

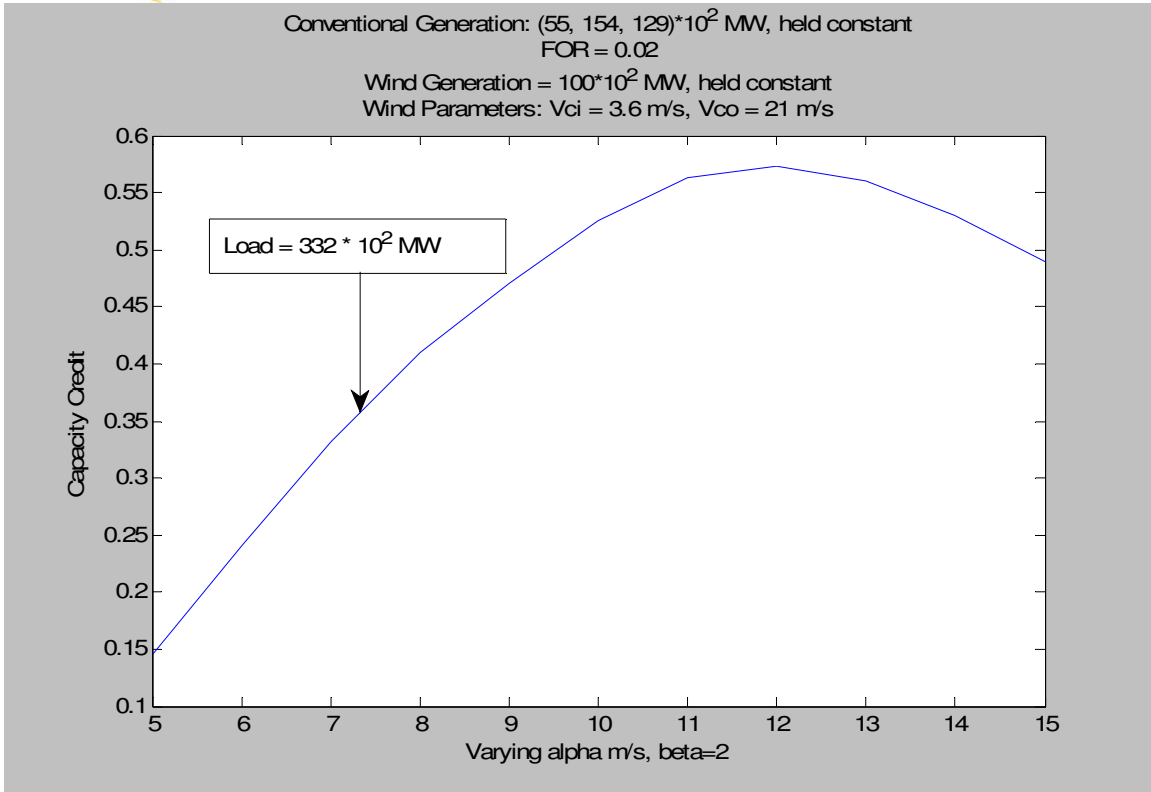

Figure 6 - Capacity Credit vs. Alpha

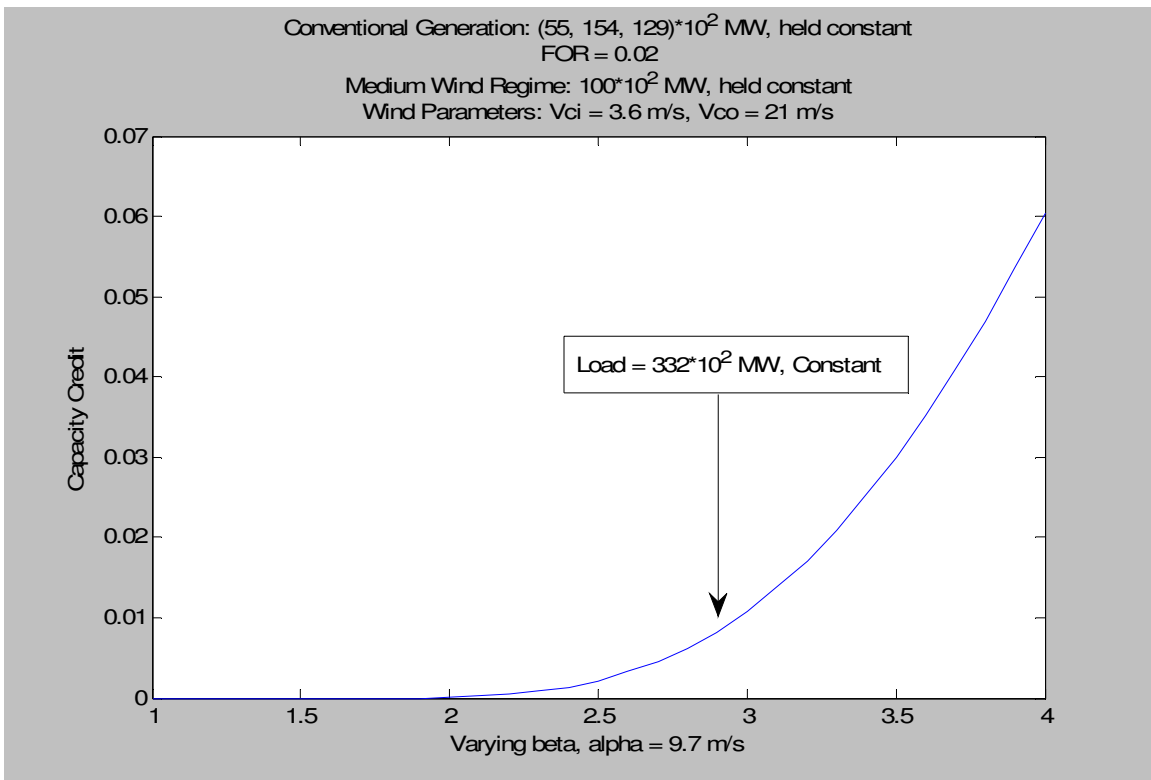

Figure 7 - Capacity Credit vs. Beta

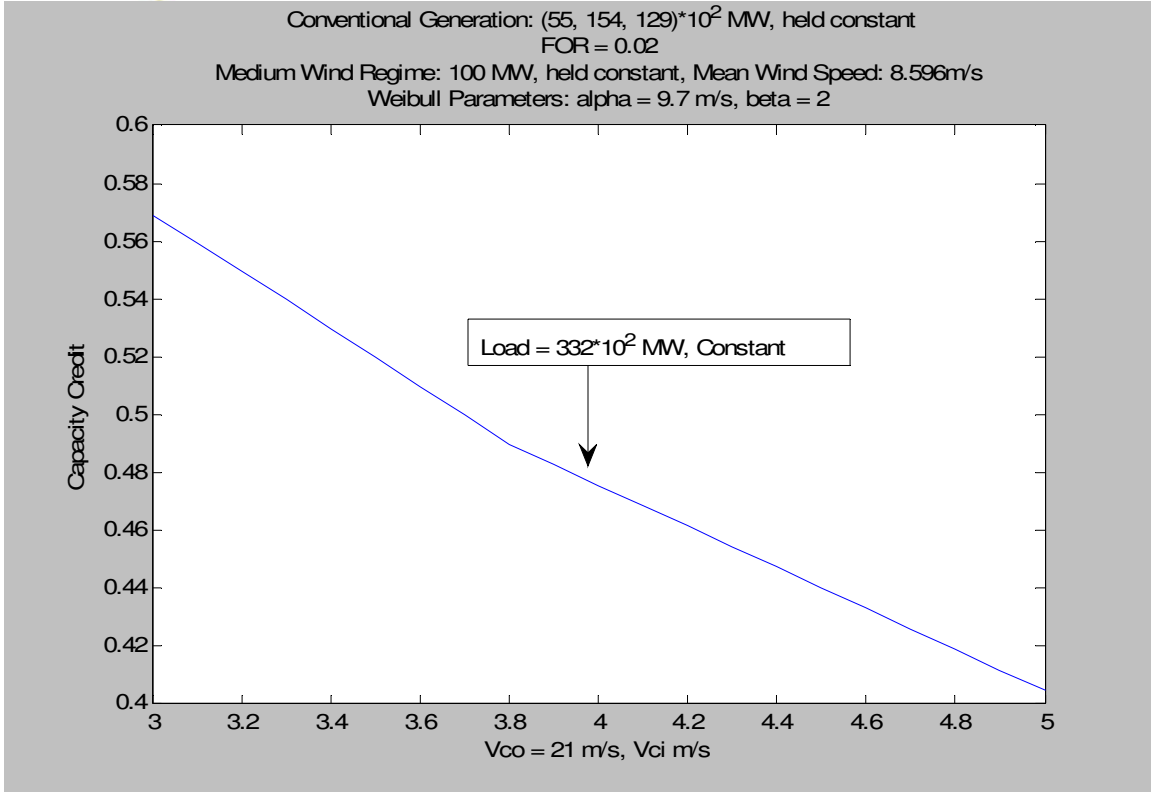

Figure 8 - Capacity Credit vs. Cut-in Speed

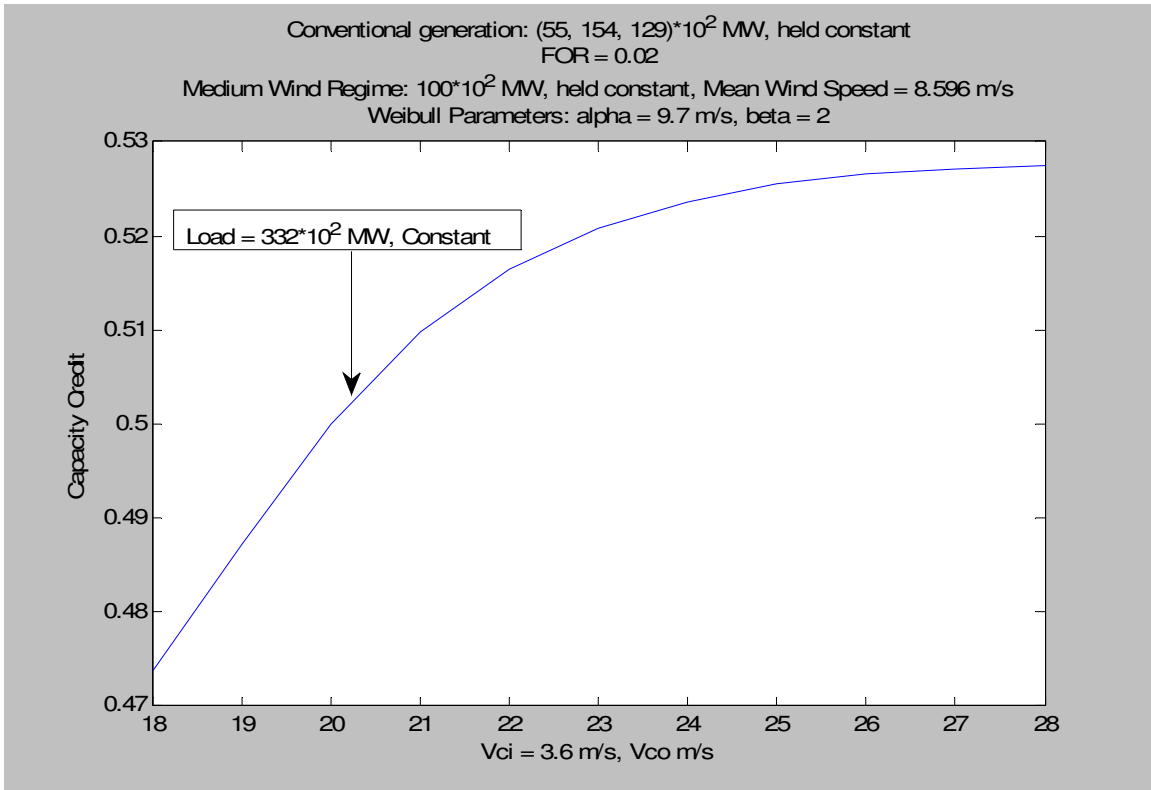

Figure 9 - Capacity Credit vs. Cut-out Speed

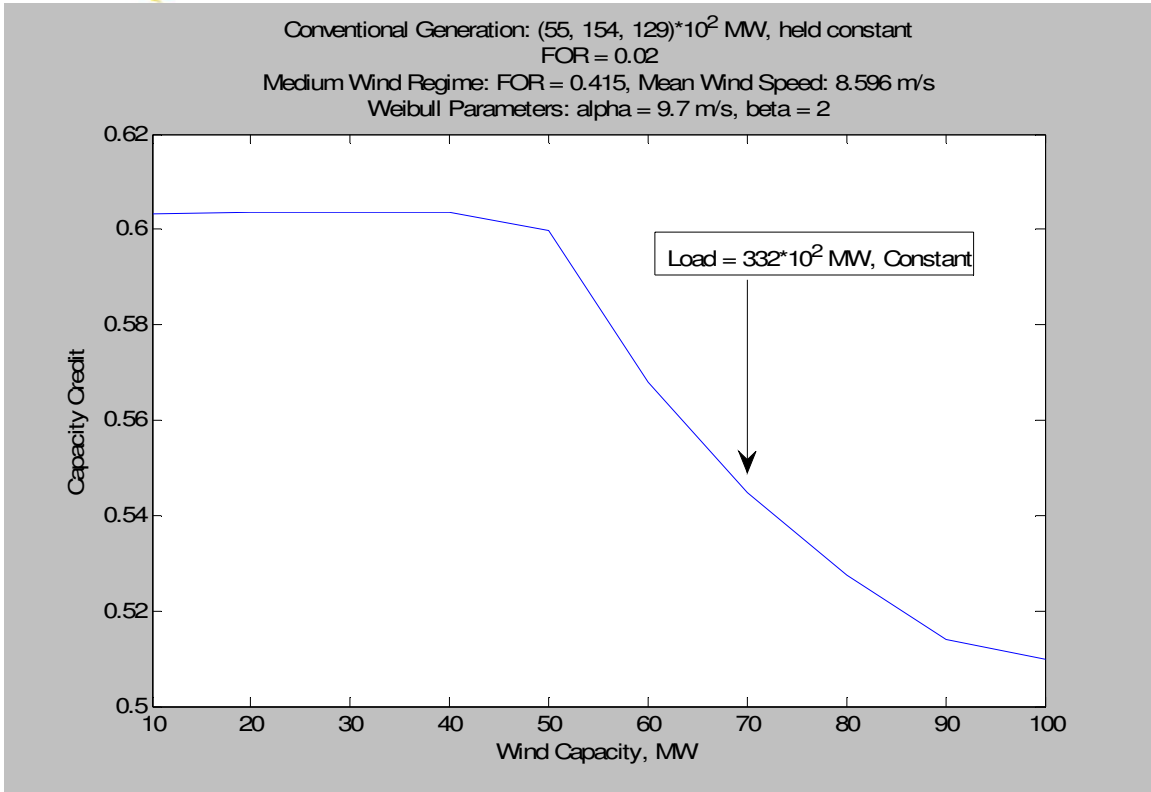

Figure 10 - Capacity Credit vs. Wind Capacity

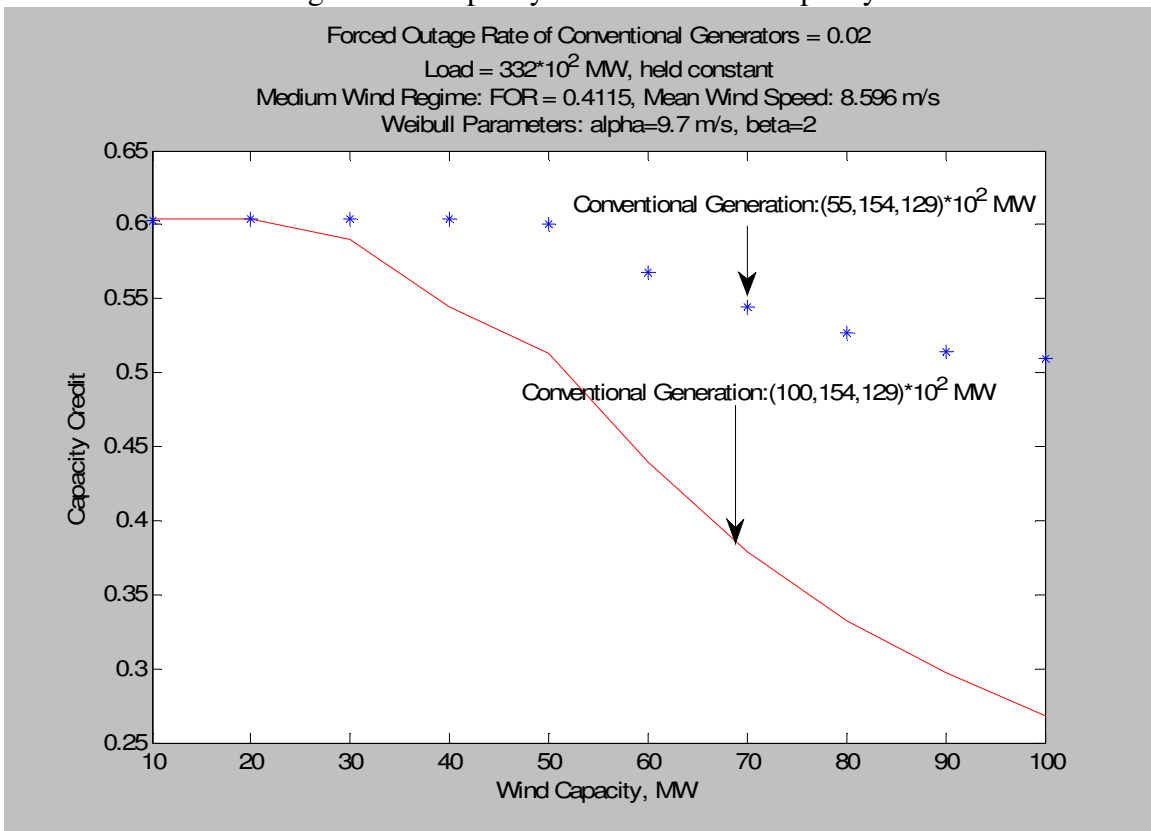

Figure 11 - Capacity Credit vs. Spinning Reserve

Conclusions

Generation of electricity from wind power has become notable over the last few decades and its impact on the overall system operation is becoming increasingly important at various levels. Quantification of capacity credit is very important because of its direct economic impact. This study has presented a simple approach to assess the capacity credit of wind electric conversion systems. The method employs forced outage rate of a wind generator and uses the classic loss of load probability calculations to estimate the capacity credit of WECS. A simple generation system is used to calculate the capacity credit in three steps using matlab code. In the generation system, real time data is considered and ELCC of wind energy obtained is 50.97% of the installed wind capacity, which can be counted in the reserve margin calculations. In addition to being simple, the approach is general enough to consider units of any rating and at any location. The influence of Weibull parameters, cut-in speed, cut-out speed, wind penetration and spinning reserve are presented graphically for different wind speed data. The graphs show the sensitivity of capacity credit to different key parameters. The capacity credit decreases rapidly as more wind capacity is added to the system without change in reliability. Capacity credit decreases with the increase in spinning reserve. With the increase in V_{co} and β , capacity credit increases. As V_{ci} increases capacity credit decreases. As scale factor α increases, the capacity credit increases initially and then decreases for high values of α . This work can be extended with a few modifications to include consideration of load variation, influence of seasonal changes.

REFERENCES

1. World Electricity Generation, IEA key world energy statistics, 2008.
2. Bent Serensen, "Renewable energy - A technical overview". *Energy Policy*, Vol. 19, No. 4, pp.386-391, May 1991.
3. G. Giebel "Wind energy has a capacity credit – a catalogue of 50+ supporting studies", *WindEng eJournal 2004*. [Online]. Available: ejournal.windeng.net/3
4. R. M. G. Castro and A. F. M. Ferreira, "A comparison between chronological and probabilistic methods to estimate wind power capacity credit," *IEEE Trans. Power Syst.*, vol. 16, no. 4, pp. 904-909, Nov.2001.
5. G. R. Pudaruth, "Capacity Credit Variation in Distribution Systems", *IEEE Power and Energy Society 2008 General Meeting*, pp. 1405-1411, June 2008.
6. K. Dragon, "Selected Properties of Wind Capacity Contributions", *IEEE Power and Energy Society 2008 General Meeting*, pp. 636-638, June 2008.
7. C. Ensslin, M. Milligan, H. Holttinen, M. O'Malley, A. Keane, "Current Methods to Calculate Capacity Credit of Wind Power, IEA Collaboration", *IEEE Power and Energy Society 2008 General Meeting*, pp. 135-137, June 2008.
8. Nagarkar R, R. Ramakumar, "An Approach to Assess Generation Reliability with Wind Electric Conversion", *40th Annual Frontiers of Power Conference*, October 2007.
9. Chang T.-J.; Wu Y.-T.; Chu C.-R. and Liao C.-M, "Assessment of Wind Characteristics and Wind Turbine Characteristics in Taiwan", *Renewable Energy*, Vol.28, No. 6, pp. 851-871(21), May 2003.